

# Lifting Hook DOMINO

Item no. 066091

Translation of the Original Instructions

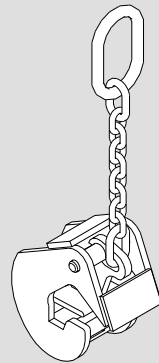

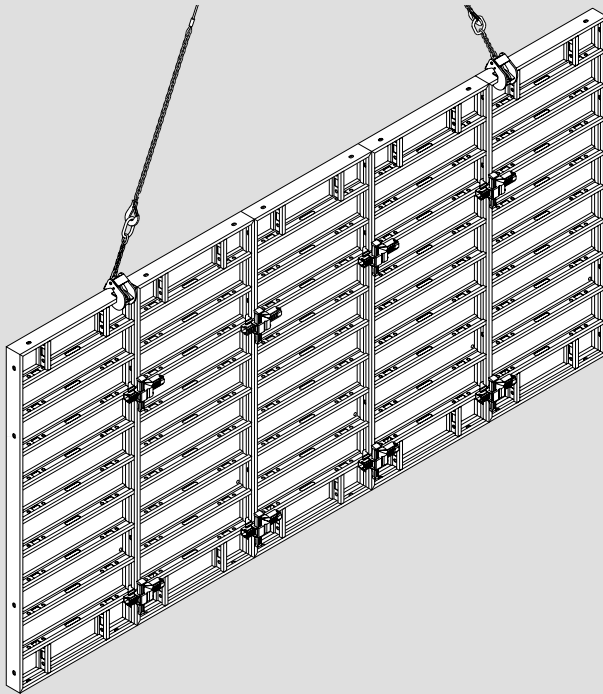

## Contents

### Translation of the Original Instructions

Overview	1
Notes	2
Intended use	4
Classification	5
Load-bearing capacity	6
Application	7
Components	10

### Appendix

EC Declaration of Conformity	12
Test instructions	14

#### Legend



Important safety instructions



Visual Check



Hints

## Overview

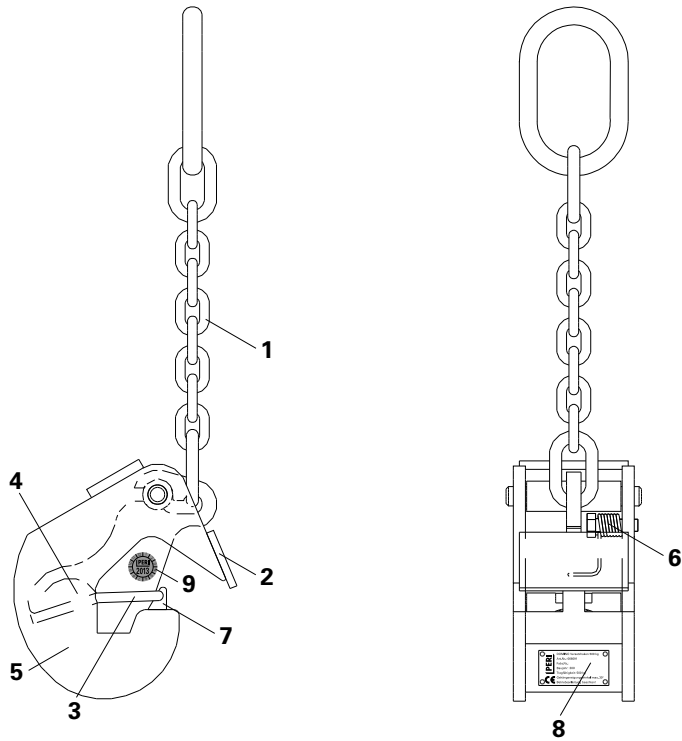

- (1) Lifting chain
- (2) Front plate
- (3) Pressure plate
- (4) Hold-down plate
- (5) Housing body

- (6) Spring
- (7) Centering bolt
- (8) Type Plate
- (9) Inspection Plate

## Notes

### Responsibilities of the employer

1. The employer can only assign those persons to independently use load-carrying equipment and lifting gear who are actually familiar with the task.
2. The employer has to ensure that the Instructions for Use provided by PERI is available, has been brought to the attention of the above-mentioned persons and is at their disposal.
3. Basically, only load-carrying equipment and lifting gear which is complete and in perfect condition may be used. Only PERI original components may be used as spare parts.
4. The employer has to ensure that the load-carrying equipment and lifting gear is subjected to an extraordinary inspection carried out by an expert after cases of damage or a particular incident which affect the load-carrying capacity, as well as after repairs.
5. The employer has to ensure that repair work on the load-carrying equipment and lifting gear is carried out only by those persons who possess the necessary knowledge and skills.
6. The employer has to ensure that the load-carrying equipment and lifting gear is inspected by an expert at a maximum of one-year intervals, and is labelled by means of a valid inspection plate.

---

### Safety instructions

1. The load-carrying equipment is to be checked for damage before every use! Load-carrying equipment with defects or loads having faulty attachment points which could influence safety during operations must not be used! (e.g. deformations, cracks, breaks, incomplete markings).
2. All persons using the load-carrying equipment must monitor the equipment before and during use for obvious defects
3. The load-carrying equipment is to be used in such a way so that persons in the area being used to transport the load are not put at risk. It is forbidden for any person to remain under a load that is being lifted!



## Notes

4. The person who attaches the load to the load-carrying equipment must be sufficiently secured against falling. The load is to be secured against tipping over and sliding!
5. The load-carrying equipment may only be used during suitable weather conditions!
6. Do not load the load-carrying equipment with more than the maximum bearing capacity!
7. Always lift up or set down loads smoothly without any jerking!
8. Persons are not to be transported!
9. Do not transport loads which rest on loose parts!
10. Ensure loads are evenly balanced when being picked up! Loads must be sufficiently stable both in their form and position so that the load does not move during transportation!
11. Ensure the steel wire rope or chains are free of knots! Do not wrap the lifting chains of the load-carrying equipment around the load to be transported or stretch over sharp edges! Untwist chains which have become twisted!
12. Ensure that the load is in a safe and secure position before releasing the load-carrying equipment.
13. Depending on the wind-exposed surface of the load and the wind speed, safety can be affected during transportation! A decision regarding safe use is to be taken on site!
14. During transport and storage, the load-carrying equipment must be positioned and secured so that it cannot fall off or slide! Do not place any loads on the load-carrying equipment!
15. During storage, the load-carrying equipment must be protected against the effects of the weather and aggressive materials! Cleaning should be carried out using a suitable and environmentally-friendly method!
16. Correctly fasten the attachment points to the load!
17. The transport of horizontal element stacks is not allowed.

## Intended use

These Instructions for Use contain information for the handling and correct application of the Lifting Hook DOMINO.

**The Lifting Hook DOMINO is classified as load-carrying equipment in terms of the German BGR 500.**

**It used for moving PERI DOMINO individual elements or element units.**

Special permission must be given by PERI GmbH if it is to be used for other applications than it has been designed for.

The Lifting Hook DOMINO is used in ambient temperatures ranging from -20°C through to +60°C.

All laws and safety regulations of each country where our product is used are to be observed at all times.

The product has been designed for commercial use only.



## Classification

### Type Plate



**Do not use the Lifting Hook DOMINO if the type plate is missing or is illegible!**

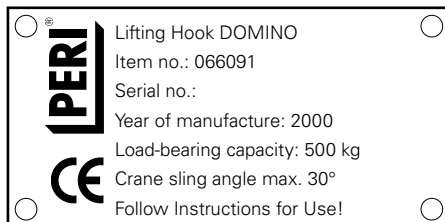

### Inspection Plate



**Do not use the Lifting Hook DOMINO if the inspection plate is missing or is illegible!**



Arrange an inspection to be carried out by an expert and then attach new type plate and/or inspection plate.

## Load-bearing capacity



**Moving of other loads is not permissible!**

**Perm. load-bearing capacity: 500 kg**

A maximum of 10 DOMINO elements 250 x 100 or a forming area of 5 x 5 m as one unit can be moved.

**Max. crane sling angle = 30°**

If the spacing  $L_1$  of the lifting hook is smaller than the individual chain length  $L$  of the lifting gear, then the crane sling angle is  $\leq 30^\circ$ .

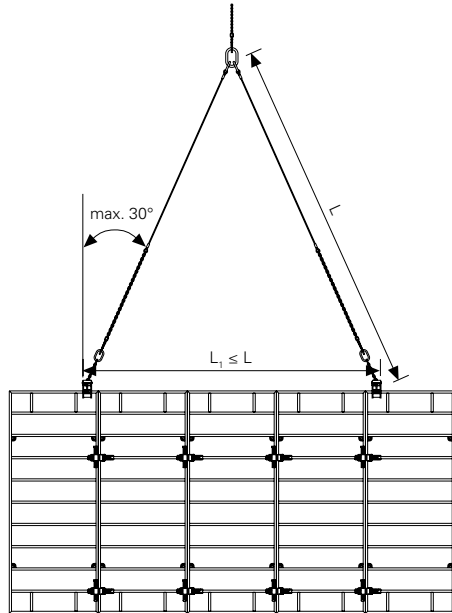

## Application

### Assembly



**Overloading! Always mount 2 lifting hooks symmetrically to the load centre for each transportation unit.**

1. Press the hold-down plate (4) against the spring resistance in order to reach its outermost position.
2. Push the lifting hook over the edge profile until the centering bolt (7) engages the slot hole of the edge profile.
3. The hold-down plate closes through the spring resistance. The lifting hook is held in a closed position through the strength of the spring, also with traction relief.

On horizontal panels: see Dismantling.



The pressure plate (3) must lie full-faced on the edge profile.



If the spring resistance is too weak, the lifting hook must be closed manually.  
Replace spring.

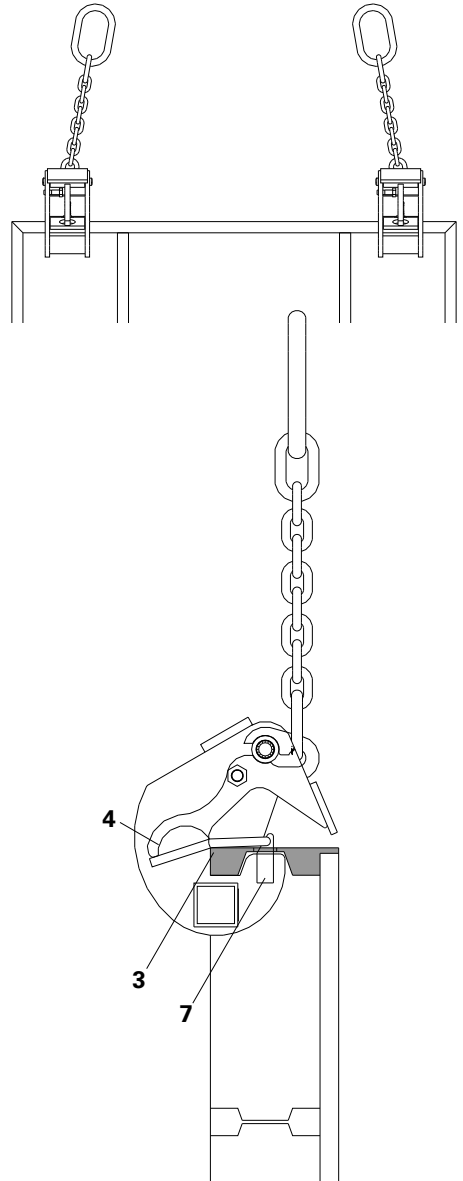

## Application

### Transport of load

#### Before lifting:

Check the attachment of the lifting hook on the element.



The lifting chain (1) must not be wound around the lifting hook. The closing function is thereby limited by the reduced tension force.

#### During transportation:



**Persons must not remain under lifted loads!**

#### After concreting:



**Do not release the panels from the concrete with the crane. Uncontrolled movement and overloading!**

#### Setting down:

Never set the load down abruptly. Do not put the lifting hook down onto obstacles.

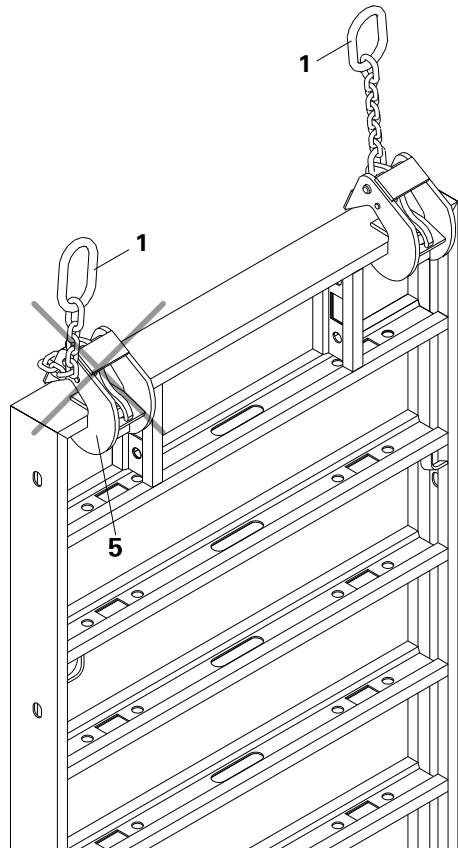

## Application

### Dismantling

On vertically-positioned panels:



**Panel can topple over!**  
**Support the panel and then release the lifting hook!**

Release the lifting hook from a position on the ground.

1. Push board or tie rod under the hold-down plate (4).
2. Press the hold-down plate against the spring resistance in order to reach the outermost position.
3. Lift the housing body (5).
4. Push the lifting hook out of the edge profile.

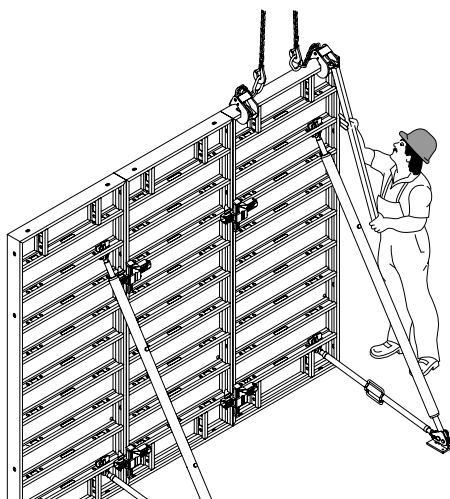
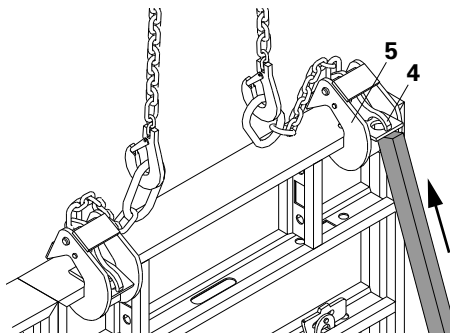

### On horizontally-positioned panels:

Ensure that there is sufficient spacing between a horizontally-positioned panel and one which is to be laid down on it, e.g. use timbers.

Spacing  $\geq 10$  cm

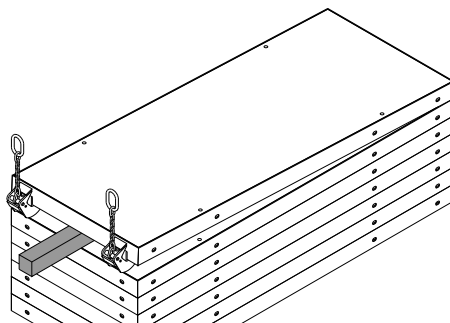

## Components

Item no.	Weight kg		
066091	6.33	<b>Lifting Hook DOMINO</b> <b>500 kg</b> For transporting DOMINO elements.	<b>Note</b> Always use 2 pieces per transportation unit. <b>Safety instructions</b> Follow Instructions for Use. Load-carrying equipment according to BGR 500. Load-carrying capacity with a crane sling angle $\leq 30^\circ = 0.5 \text{ t}$ .

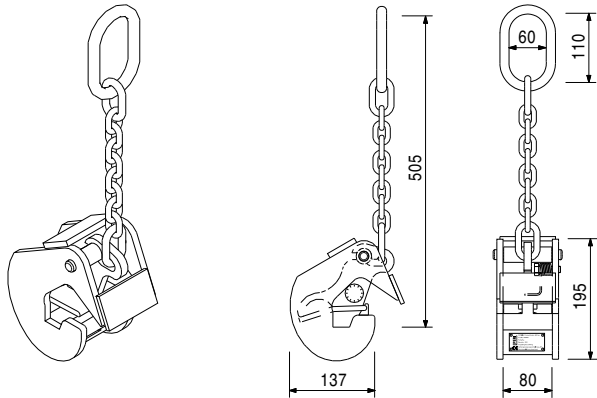



# EC Declaration of Conformity

This document is a translation into English from the German original.

## EC Declaration of Conformity

as defined in EU Directive 2006/42/EC

Appendix II,1.A

**Person residing within the Community authorised to compile the relevant technical documentation:**

Dipl.-Ing. Rainer Bolz  
PERI GmbH  
Rudolf-Diesel-Strasse 19  
89259 Weissenhorn

**Description and identification of the machinery:**

Product group:	Wall Formwork
Type:	Load-Carrying Equipment
Item no.:	066091
Trade name:	Lifting Hook DOMINO

**It is expressly declared that the machinery fulfils all relevant provisions of the following EU Directives.**

EU Machine Guidelines 2006/42/EC

**Reference to the harmonised standards used, as referred to in Article 7 Annex 2:**

EN 13155: 2009-08  
EN 14121: 2009-09  
EN 1677  
EN 818

Weissenhorn, 01.07.2014

**Manufacturer**  
PERI GmbH  
P.O. Box 1264  
89259 Weissenhorn

-----  
**Head of Product Development**

Dipl.-Ing. Rainer Bolz  
PERI GmbH



## EC Declaration of Conformity

### **EG-Konformitätserklärung**

im Sinne der EG-Richtlinie 2006/42/EG

Anhang II,1.A

**In der Gemeinschaft ansässige Person, die bevollmächtigt ist, die technischen Unterlagen zusammenzustellen:**

Dipl.-Ing. Rainer Bolz  
PERI GmbH  
Rudolf-Diesel-Straße 19  
89259 Weißenhorn

**Beschreibung und Identifizierung der Maschine:**

Produktgruppe:	Wandschalung
Typ:	Lastaufnahmemittel
Artikel-Nr.:	066091
Handels-Bez.:	Versetzhaken DOMINO

**Es wird ausdrücklich erklärt, dass die Maschine allen einschlägigen Bestimmungen der folgenden EG-Richtlinien entspricht:**

EG-Maschinenrichtlinie 2006/42/EG

**Fundstelle der angewandten harmonischen Normen entsprechend Artikel 7, Absatz 2:**

EN 13155: 2009-08  
EN 14121: 2009-09  
EN 1677  
EN 818

Weißenhorn, 01.07.2014

**Hersteller**  
PERI GmbH  
Postfach 1264  
89259 Weißenhorn

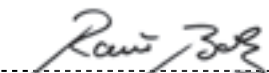

**Leitung Produktentwicklung**

Dipl.-Ing. Rainer Bolz  
PERI GmbH

## Test instructions

### 1. Area of application

These test instructions are valid for regularly recurring inspections, or inspections carried out after any unusual occurrence, on PERI GmbH manufactured, marketed or rented load-carrying equipment.

Description:

#### Lifting Hook DOMINO

Item no.: 066091

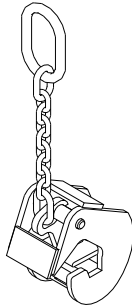

### 2. Purpose

Due to regularly recurring inspections of the load-carrying equipment, it can be ensured that operational and functional reliability is guaranteed and any possible risk of accidents is eliminated.

Inspections must take place at regular intervals.

(In Germany, at least every 12 months!)

Depending on the operational conditions, shorter intervals may also be required.

### 3. Responsibilities

The employer or his appointed safety officer is responsible for the instigation of regularly recurring safety inspections of the load-carrying equipment. Safety inspections on the load-carrying equipment are only to be carried out by trained personnel.

For ultrasonic and crack detection tests, the guidelines and implementation requirements of the appropriate national and international regulations of the corresponding organizations apply.

For Germany, this is the DGZFP (German Society for Non-Destructive Testing).

### 4. Procedures

#### 4.1 Arranging the inspection

The employer arranges the inspection with the manufacturer of the load-carrying equipment or a suitable service provider, or can carry out the inspection himself if an expert is present as an inspector.

#### 4.2 Implementing the inspection

The inspection includes a visual and functional check. Implementation of anything beyond the usual scope of testing is subject to the discretion of the inspector, and can extend to the following checks.

#### Visual inspection:

- wear (especially bolts), corrosion.
- availability of all components.
- chain (see DIN 685 Part 5, Section 4.1 and 4.2).
- cracks on welding seams and individual components.
- deformation of the load-carrying equipment.

#### Functional test:

- spring for flap.
- free and easy movement of moving parts.

## Test instructions

- attaching the lifting hook to a DOMINO element.

### **Special test:**

This is carried out if there is any doubt regarding the reliability of deformations and/or wear during the visual inspection.

### **Measures:**

If any defects have been determined as a result of the safety inspection, these must be eliminated according to specifications provided by the expert. Subsequently, a new inspection is to be performed.

Within the framework of repair work carried out on the load-carrying equipment, welding may only be undertaken by companies which have an appropriate welding suitability certificate according to national and international regulations or standards.

In Germany: "Großer Eignungsnachweis" according to DIN 18800, Part 7, Paragraph 6.2. This is required according to DIN 15429.

## The optimal System for every Project and every Requirement



Wall Formwork



Column Formwork



Slab Formwork



Climbing Systems



Tunnel Formwork



Bridge Formwork



Shoring Systems



Construction Scaffold



Facade Scaffold



Industrial Scaffold



Access



Protection Scaffold



System-Independent Accessories



Services



**PERI Formwork Systems Inc.**  
 45 Nixon Road  
 Bolton, ON L7E 1K1  
 Canada  
 Tel. +1 (905) 951 - 5400  
 Fax +1 (905) 951 - 5454  
 info@peri.ca  
 www.peri.ca